



Since 1952

We Manufacture a Quality Made in the U.S.A. Steam Generator

All of our 100% electric Steam Generators are built in accordance with the highest possible approvals ASME Miniature Code, National Board of PVI Shop Inspection UL, ETL, CSA and meet OSHA requirements. CE Available

Oven & Proofers
Typical Oven Installations

Revolving Oven

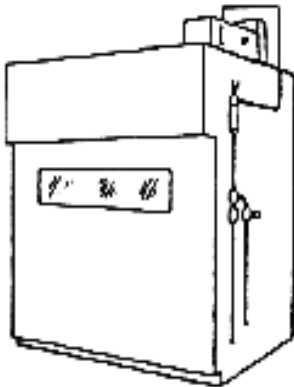

Multiple Decks

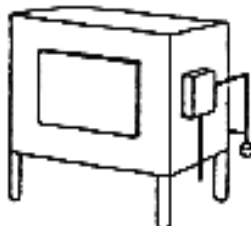
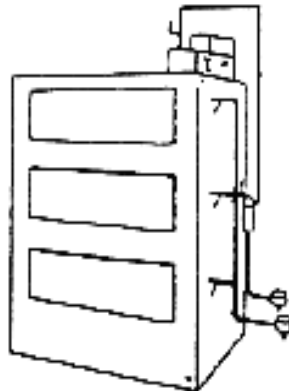

**Convection or
Single Deck**

Any oven, no matter its age, can be retro-fitted. If you have an oven that originally contained flash or float steam it can be retro-fitted.

**"Hearth Steam" Package Generators for
Oven & Proof Boxes**

- 100% Culinary Steam ideal for proofing and baking hard crusted bread and rolls.
- Easy to install-all you need is water & electricity.
- Safe to use no flame, fuel or ventilation required.
- Completely Automatic - Your apprentice bakers or helpers can operate.
- Increase your profits through better quality bread baking.
- Heat up time 8-10 minutes.
- Can be put on timer or push button.
- No fire wall.

Equipment	Steam Generator Model			
	Capacity	Electric Oven	Gas Oven	Humidity Heat
Single Deck or Convection	6 Bun Pan	LG-5	LG-10	
	9 Bun Pan	LG-10	LG-15	
	12 Bun Pan	LG-15	LG-20	
Multiple Deck or Convection	9 Bun Pan	LG-10	LG-10	
	12 Bun Pan	LG-10	LG-15	
	18 Bun Pan	LG-20	LG-30	
	24 Bun Pan	LG-25	LB-40	
Rotary	30 Bun Pan	LB-40	LB-50	
	9 Bun Pan	LG-15	LG-25	
	18 Bun Pan	LG-20	LG-30	
	24 Bun Pan	LG-25	LB-40	
Revolving	36 Bun Pan	LB-50	LB-60	
	48 Bun Pan	LB-60	LB-80	
	15 Bun Pan	LG-15	LG-25	
	20 Bun Pan	LG-20	LG-30	
Proof Boxes	24 Bun Pan	LG-25	LB-40	
	36 Bun Pan	LB-40	LB-50	
	48 Bun Pan	LB-60	LB-80	
	250 Cu. Ft.	LG-5		LG-10
	450 Cu. Ft.	LG-10		LG-20
	600 Cu. Ft.	LG-15		LG-30
	1000 Cu. Ft.	LG-30		LB-60
	2600 Cu. Ft.	LB-60		LB-100

NOTE: Generators can be installed at top or on side of oven/ proofer. State configuration and capacity when ordering. Subject to change without notice.

NOTE: Direct fire gas ovens should increase sizing by minimum of one BHP

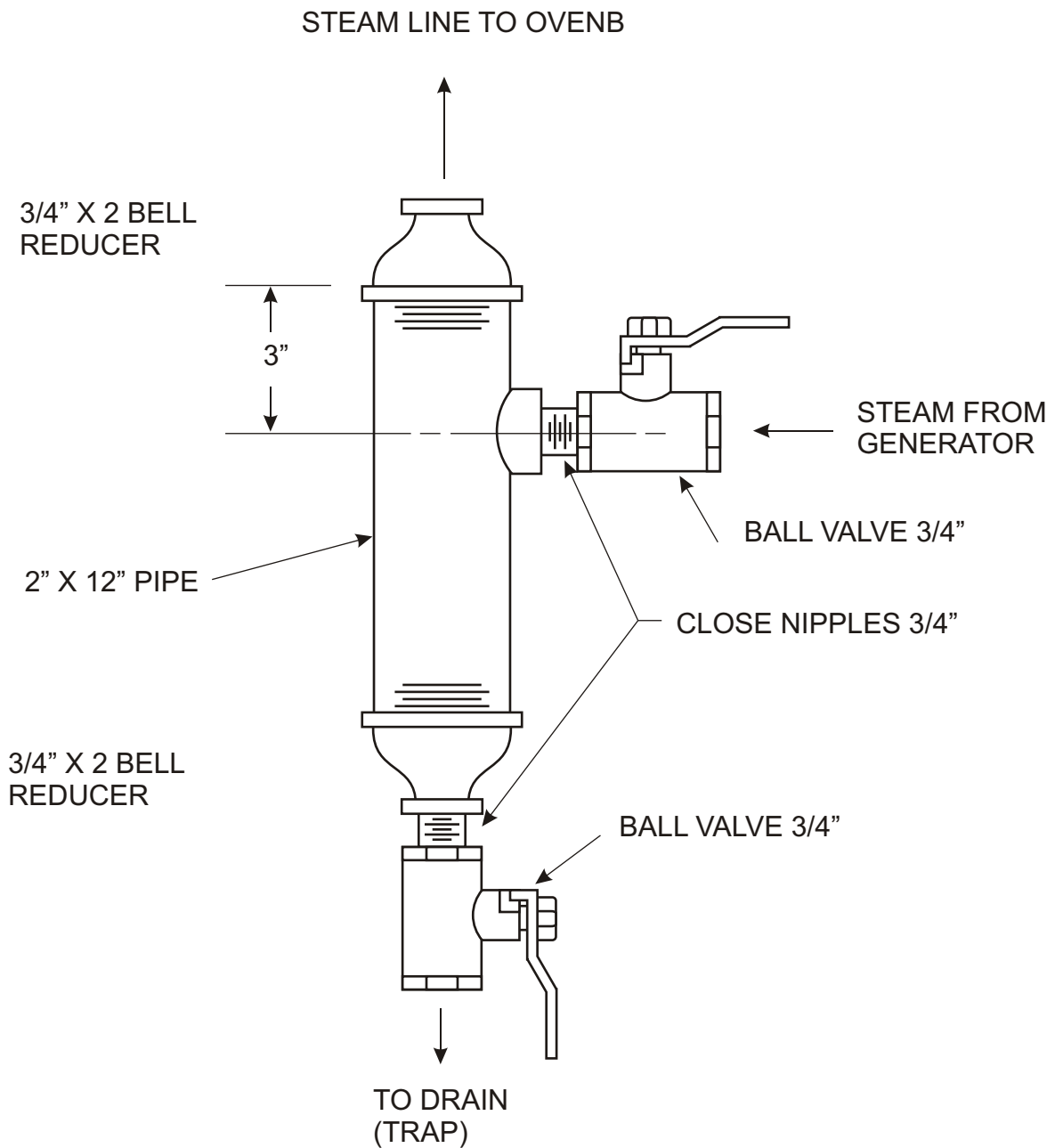

REVISIONS			ELECTRO-STEAMM GENERATOR CORP.		
NO.	DATE	DESCRIPTION	1000 BERNARD STREET ALEXANDRIA, VA 22314		
			TITLE		
			WATER DIVERTER FOR BAKING OVEN (TRAP)		
			DRAWN BY	CHECKED BY	DRAWING NO.
			JAK		
			DATE	SCALE	COMP-9503-A

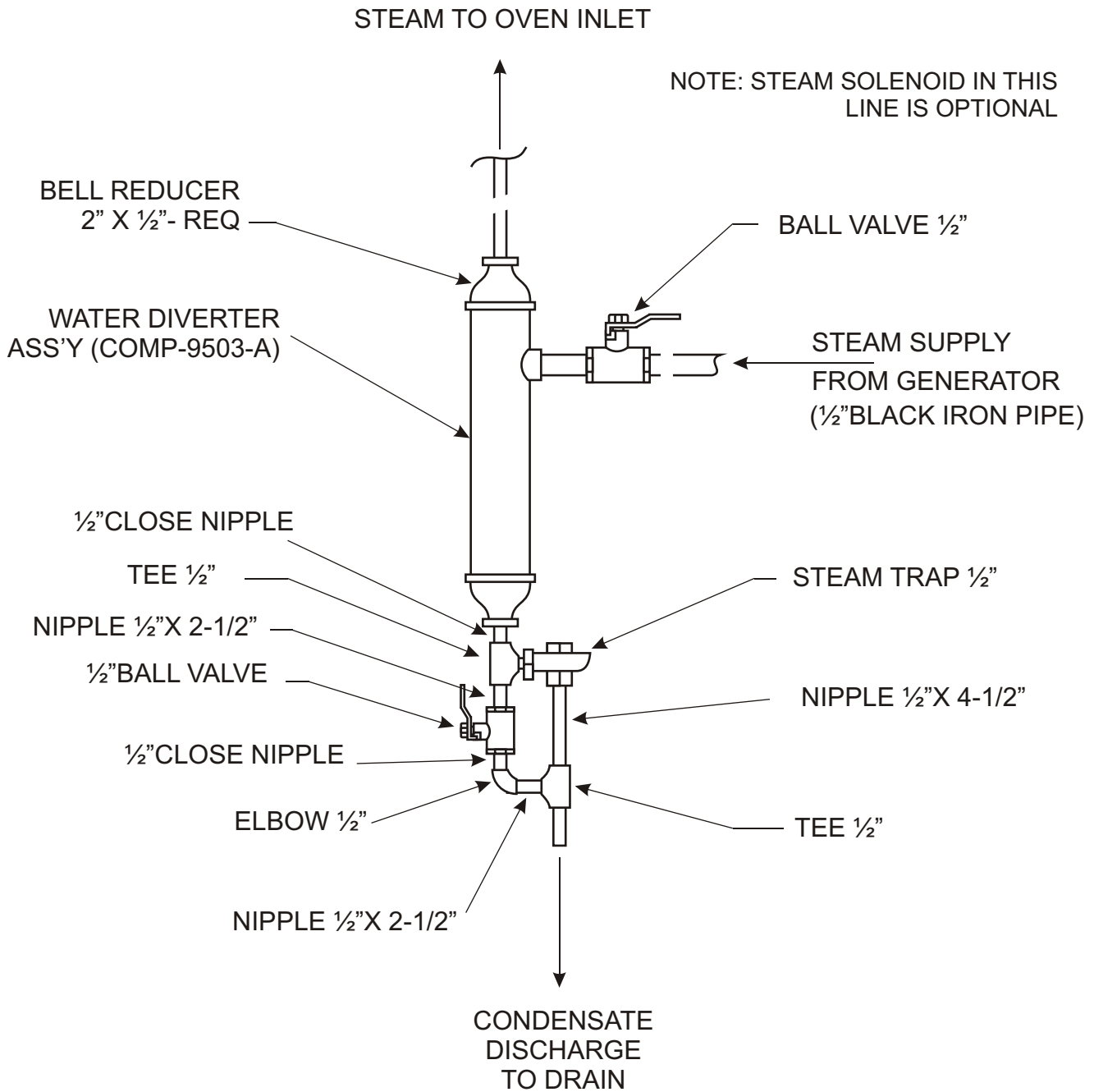

REVISIONS

NO.	DATE	DESCRIPTION

ELECTRO-STEAM GENERATOR CORP.

1000 BERNARD STREET ALEXANDRIA, VA 22314

TITLE **STEAM / WATER DIVERTER
AND TRAP ASSEMBLY**

DRAWN BY **JAK**

CHECKED BY

DRAWING NO.

DATE

SCALE

COMP-9503-B